

JULY 2022 HALF ACRE PROJECT THRESHOLD CHANGES

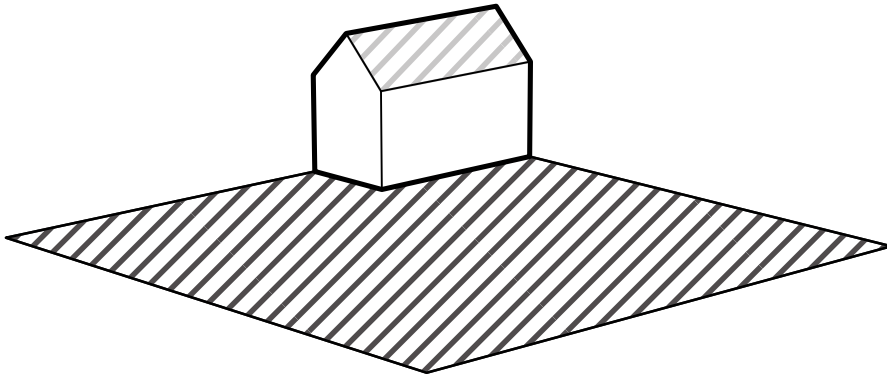

Jurisdictional Trigger Prior to 7.1.2022 - 1.0 Acre

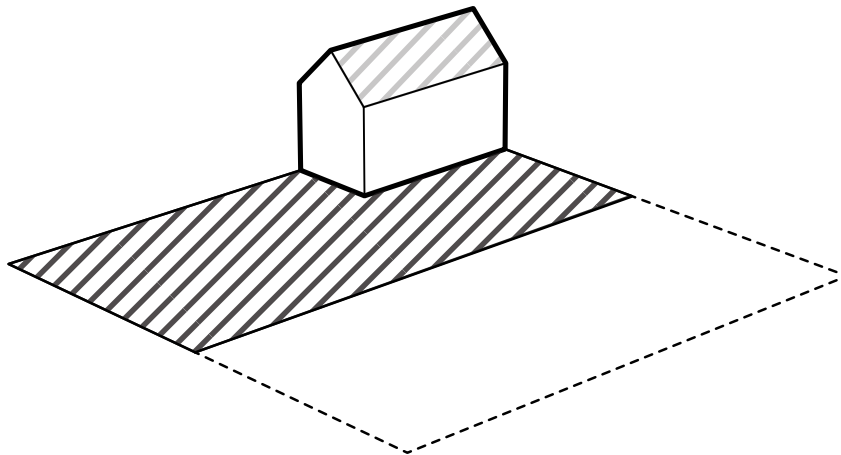
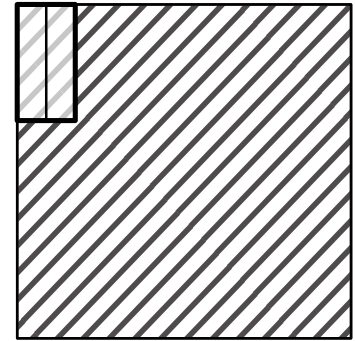

Jurisdictional Trigger After 7.1.2022 - 0.5 Acre

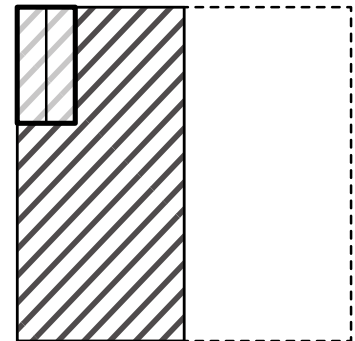

 Impervious Surface

Beginning 7.1.2022 there will be a change in the threshold for stormwater operational permit coverage (3-9050)¹

On 7.1.2022, barring some transitional exemptions², a discharge from new development equal to or greater than $\frac{1}{2}$ acre of impervious surface or a discharge from the redevelopment of an existing impervious surface if the redeveloped portion of the existing impervious surface is equal to or greater than $\frac{1}{2}$ acre will be required to apply for stormwater operational permit coverage.

Transitional Exemptions³:

- Projects that have submitted complete applications for all applicable state, local, federal, and discharge permits and commence to substantially construct their projects prior to 7.1.2024
- Projects that have obtained all applicable state, local, federal, and discharge permits and commence to substantially construct their projects prior to 7.1.2024
- Projects that require no other state, local, federal or discharge permits and commence to substantially construct their projects prior to 7.1.2024
- The construction, redevelopment, or expansion is a public transportation project, and as of July 1, 2022, the Agency of Transportation or the municipality principally responsible for the project has initiated right-of-way valuation activities or determined that right-of-way acquisition is not necessary, and substantial construction of the project commences within five years from July 1, 2022.

This change in threshold does not affect the 5000sqft expansion threshold of one acre (1.0 acre)

¹General Permit 3-9050 1.3.B

²General Permit 3-9050 1.5.F

³Transitionally exempt projects that make subsequent project amendments that potentially affect water quality should contact a stormwater reviewer