



Design guide | Vermont

ECOFLO[®]

Linear biofilter EL15 model series



DEPARTMENT OF ENVIRONMENTAL CONSERVATION

Drinking Water & Groundwater Protection Division

THIS IS SUBJECT TO PROVISIONS OR CONDITIONS LISTED IN PERMIT

Permit #: [2024-02-R0](#)

Date: [March 29, 2024](#)

Design guide | Vermont – Ecoflo[®] linear biofilter EL15 model series

This guide contains specific information required to plan the installation of an **Ecoflo linear biofilter EL15 model series** treatment system in the state of Vermont. Specifications not described in the design manual must adhere to regulations. The installation must be performed by an authorized installer. For more information, contact your local distributor or Premier Tech at **1 800 632 6356**.

TABLE OF CONTENTS

- 1. General description 3
 - 1.1 Gravity distribution 3
 - 1.2 Primary treatment 3
 - 1.3 Dosing and distribution 3
 - 1.4 Ecoflo linear biofilter EL15 4
- 2. Treated effluent quality 4
- 3. Wastewater system component design and specification 5
 - 3.1 System configuration 5
 - 3.2 Design flow 5
 - 3.3 Primary/septic tank 6
 - 3.4 Effluent filter 6
 - 3.5 System dosing 6
 - 3.6 Design criteria 8
 - 3.7 Configuring the dispersal area and the Ecoflo linear biofilter EL15 9

Continued on next page

3.8 Sampling device	13
3.9 Lifespan of a filtration pad	13
3.10 Final dispersal	13
4. Location of wastewater system components	14
4.1 Primary/septic tank installation conditions	14
4.2 Rewatec dosing distribution box	14
4.3 Ecoflo linear biofilter EL15	14
5. Effluent dispersal	14
5.1 Hydraulic conductivity	14
5.2 Vertical separation to limiting zone	15
5.3 Dispersal bed and trench surface sizing	15
5.4 System ventilation	18
5.5 Low-pressure system configuration	19

1 GENERAL DESCRIPTION

The Ecoflo linear biofilter EL15 is certified according to the ANSI/NSF Standard 40 Class 1. This certification includes a primary/septic tank equipped with an effluent filter and a number of treatment modules (proportional to the flow to be treated) positioned on a sand layer. Treatment modules are designed to treat up to 6.8 gallons per linear foot of filtration pad (84 L/m-d).

The figure below represents a schematic of an Ecoflo linear biofilter EL15 system.

1.1 GRAVITY DISTRIBUTION

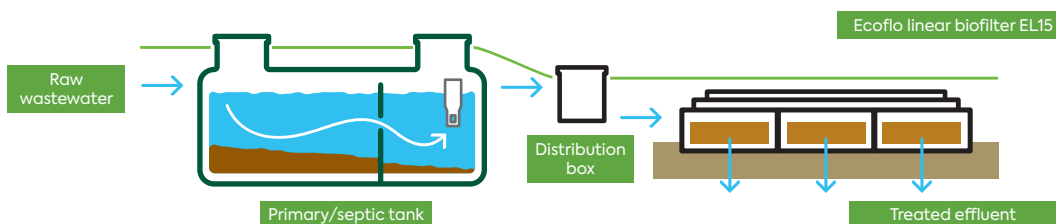

Figure 1.1 | Ecoflo linear EL15 biofilter system with gravity wastewater distribution

1.2 PRIMARY TREATMENT

The primary/septic tank is the first step of the treatment train. The primary/septic tank clarifies wastewater by letting suspended solids settle to the bottom and prevents clogging from occurring in the secondary or advanced secondary treatment system by retaining floating matter. An effluent filter is installed at the primary/septic tank's outlet.

The primary/septic tank and the effluent filter must comply with local regulations.

1.3 DOSING AND DISTRIBUTION

The septic/primary tank effluent flows by gravity to be distributed evenly onto the Ecoflo linear biofilter EL15 laterals.

Depending on site conditions and system configuration, even distribution between the laterals can be enhanced by different methods:

- Distribution box
- Rewatec dosing distribution box
- Pumped to a distribution box
- Pumped to low-pressure pipes

The figures below represent typical schematics of the Ecoflo linear biofilter EL15 configuration involving some of these distribution methods.

1.3.1 Gravity distribution

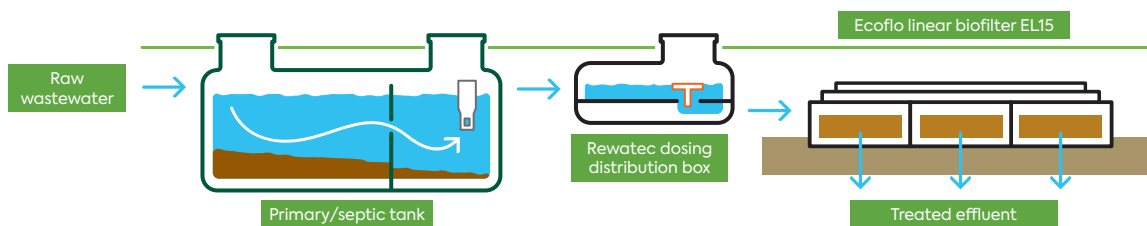

Figure 1.3.1 | Ecoflo linear EL15 biofilter system with gravity distribution

1.3.2 Pump-to-gravity distribution

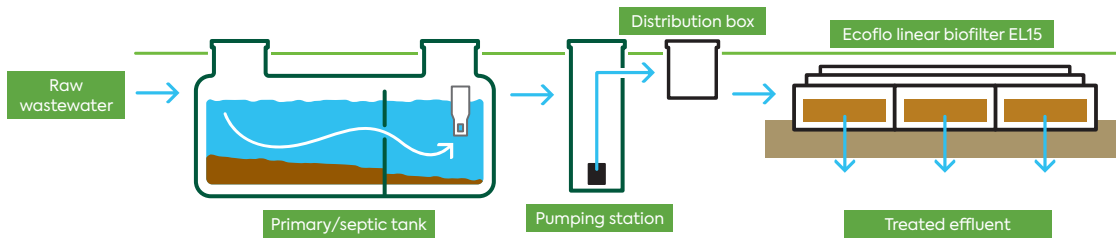

Figure 1.3.2 | Ecoflo linear EL15 biofilter system with pump-to-gravity distribution

1.3.3 Low-pressure distribution

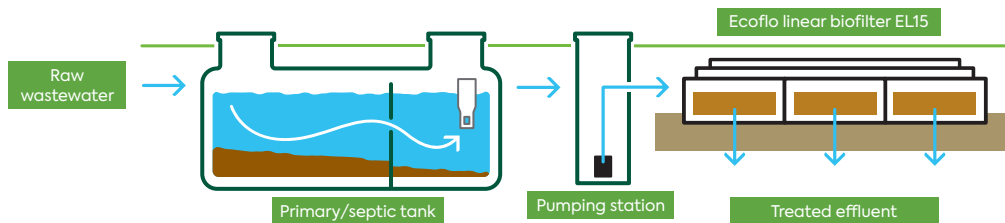

Figure 1.3.3 | Ecoflo linear EL15 biofilter system with low-pressure distribution

1.4 ECOFLO LINEAR BIOFILTER EL15

Wastewater travels through the perforated distribution channel of each treatment module and is dispersed onto the surface of the filtration pads. Treatment begins as wastewater percolates through the pads. Particles are filtered while microorganisms within the pads perform an aerobic degradation of organic matter. Open air channels support aerobic bacterial growth. Treatment is completed in the sand layer beneath the pads. Treated water returns to the environment by infiltrating into the soil directly beneath the Ecoflo linear biofilter EL15. The pads reduce oxygen demand in the sand and minimize clogging by removing a significant fraction of the organic matter that would have otherwise generated biosolids within the sand. This treatment system makes it possible for treated wastewater to meet requirements of ANSI/NSF Standard 40 Class 1 (for example, less than 20 mg/L in terms of BOD₅ and TSS).

The operating principle of the Ecoflo linear biofilter EL15 allows permanent or intermittent use without requiring any special precautions and without affecting the quality of the treatment. No special action is required from the owner to get the system up and running. The minimum number of treatment modules is determined by the total daily flow of water to be treated (refer to Table 4 below), according to local regulations.

2 TREATED EFFLUENT QUALITY

When treating domestic wastewater up to the design flows and loads, a properly maintained Ecoflo linear biofilter EL15 system will exceed the performance requirements of ANSI/NSF Standard 40 Class 1. Actual test results, established through analytical methods described in the ANSI/NSF Standard 40, averaged 8.1 mg/L in CBOD₅ and 3.9 mg/L in TSS over the 6-month testing period.

Table 1: Ecoflo linear biofilter EL15 treated effluent quality

	Influent	Ecoflo EL15 effluent
TSS	231 mg/L	3.9 mg/L
CBOD ₅	199 mg/L*	8.1 mg/L
pH	7.0**	6.9

* Influent concentrations are expressed in terms of BOD₅.

** Median

The Ecoflo linear biofilter EL15 does not require any acclimation or start-up period to consistently provide effluent quality demonstrated in the table above. This makes it the perfect system for secondary homes, seasonal homes, or any other intermittent use applications. The Ecoflo linear biofilter EL15 has also been specifically developed and tested for cold-climate applications. Treatment efficiency is not subject to significant variation with ambient air temperature fluctuations.

3 WASTEWATER SYSTEM COMPONENT DESIGN AND SPECIFICATION

3.1. SYSTEM CONFIGURATION

The designer of an Ecoflo linear biofilter EL15 system is responsible for the configuration and sizing of the system components, treatment modules, Rewatec dosing distribution box, and other peripheral component specifications. They are also responsible for the configuration and sizing of treated effluent dispersal or final disposal, and of construction details per the Ecoflo linear biofilter EL15 design guide. Design must also comply with certification requirements and specifications, and must adhere to local regulations as applicable.

3.2. DESIGN FLOW

The design flow must be calculated according to applicable local regulations, which usually define daily flow based on the number of bedrooms or occupants, the number of water fixtures, and/or square footage.

Premier Tech Water and Environment does not recommend the use of a garbage disposal unit. If one is being used, you must follow applicable local requirements for tank and dispersal area sizing.

Backwash from domestic water treatment devices may adversely affect a septic system. Premier Tech does not recommend discharging them into your septic system. Discharge them into an independent dispersal component if local jurisdiction allows for one. Otherwise, you must follow local regulations for tank and dispersal area sizing. In addition to these, Premier Tech recommends to:

- Have your drinking water analyzed by an accredited laboratory (physico-chemical and aesthetic analyses).
- Consult a drinking water treatment professional to design your system based on the results of this analysis.
- Ensure that the system used complies with ANSI/NSF 44.

To reduce the frequency of backwashing, as well as the volume of water required and the quantities of salt used, Premier Tech recommends:

- The use of a DIR (Demand Initiated Regeneration) softener system.
- To avoid all-in-one solutions and choose drinking water treatment chains according to the specific contaminants to be removed (for example, filters for Fe, Mn, etc.).
- The use of an up-flow softener system.
- In the presence of a downflow softener system, to ensure that the latter does not use more than a 6 lb salt/ft³ (91 kg/m³) medium.
- To have the system calibrated by a professional to ensure optimal operation.
- To follow the instructions in the operation and maintenance guide for your system.

Make sure your drinking water professional coordinates with Premier Tech Water and Environment, who will assist you with your project.

3.3 PRIMARY/SEPTIC TANK

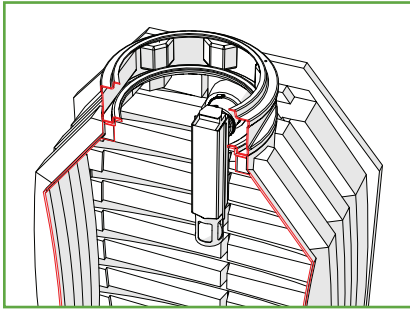

As per ANSI/NSF Standard 40 certification, the primary/septic tank must have a minimum effective capacity of 1.9 times the daily design flow. The tank must be rectangular in shape and/or composed of two rectangular tanks in series. It must comply with local regulations.

Choosing a primary/septic tank that is larger than required may improve the primary treatment performance of any septic system.

An existing primary/septic tank can be used instead of a new one. Its condition must be carefully inspected before being used for primary treatment. An NSF 46 certified effluent filter must be installed at its outlet if it is not already equipped with one.

3.4. EFFLUENT FILTER

As per requirements, the septic tank must be equipped with an effluent filter. The effluent filter extends the life of any treatment system by keeping solids in the primary/septic tank. The effluent filter is especially important if the household is equipped with a sewage pump or any other appliance that is susceptible to increase the suspended solids content in the wastewater. These appliances may jeopardize the system’s operation and affect its performance. An effluent filter will also prevent solids from reaching the effluent pump. No garbage disposal unit should be installed on the primary/septic system.

Effluent filters used with the Ecoflo linear biofilter EL15 must comply with ANSI/NSF standard 46 and filter particles 1/16” (1.6 mm) and larger. They are normally installed on the final outlet of the septic tank. While many different brands of effluent filters meet those specifications, Premier Tech recommends the Polylok PL-122 effluent filter or an equivalent.

3.5 SYSTEM DOSING

The Ecoflo linear biofilter EL15 is fed on demand. The doses can be fed by gravity, conveyed by a pump to a distribution box, or pressure dosed (low-pressure pipes). Depending on site constraints, system runs can be either end-fed (figure 3.5.1.1, example of end feeding using 2 Rewatec dosing distribution boxes) or center-fed (figure 3.5.1.2).

Table 2: Feeding modes - Limit of application

Mode	Gravity		Low pressure
Maximum length of a run	60' (18 m)		> 60' (18 m)*
	15 modules		> 15 modules*
Maximum total number of modules per dosing device	Rewatec dosing distribution box: 36 modules	Pump to distribution box: per design	per design

* Length of a run may exceed 60' or 15 modules. Limitation in length or number of modules is based on design according to site constraints and pump capacity.

3.5.1 Rewatec dosing distribution box (gravity distribution)

To improve the distribution of gravity-fed systems, Premier Tech Water and Environment has designed the Rewatec dosing distribution box. Wastewater from the primary/septic tank flows by gravity to the Rewatec dosing distribution box. The device's outlets divide wastewater into measured doses to ensure an even distribution to each run. The doses then flow by gravity into the distribution channel of each run. The Rewatec dosing distribution box's maximum capacity is 18 gallons (68 liters) per event.

The Rewatec dosing distribution box is designed to perform both dosing and distribution. As effluent from the primary/septic tank accumulates in the first compartment of the system, the dosing device floats upward. As the dosing device floats up, it prevents water from entering the second section of the system. Once the dosing plate reaches the top, effluent will begin to flow through the central aperture. As the plate descends, accumulated effluent drains through the center of the plate and flushes in to the second compartment, where up to five 4” (100 mm) outlet pipes serve as a distribution box.

The maximum length of a gravity fed system is 60' (18 m) per run (fifteen modules) and/or a total number of modules not exceeding thirty-six (36), as summarized in table 2 above. A system with more than thirty-six modules requires a second Rewatec dosing distribution box, as shown in figure 3.5.1.1, or low-pressure pipe distribution. Runs exceeding 60' (18 m) in length require low-pressure distribution.

The Rewatec dosing distribution box delivers a dose comprised between 0.12 USG/ft to 0.32 USG/ft (1.5 to 4 L/m) of treatment modules.

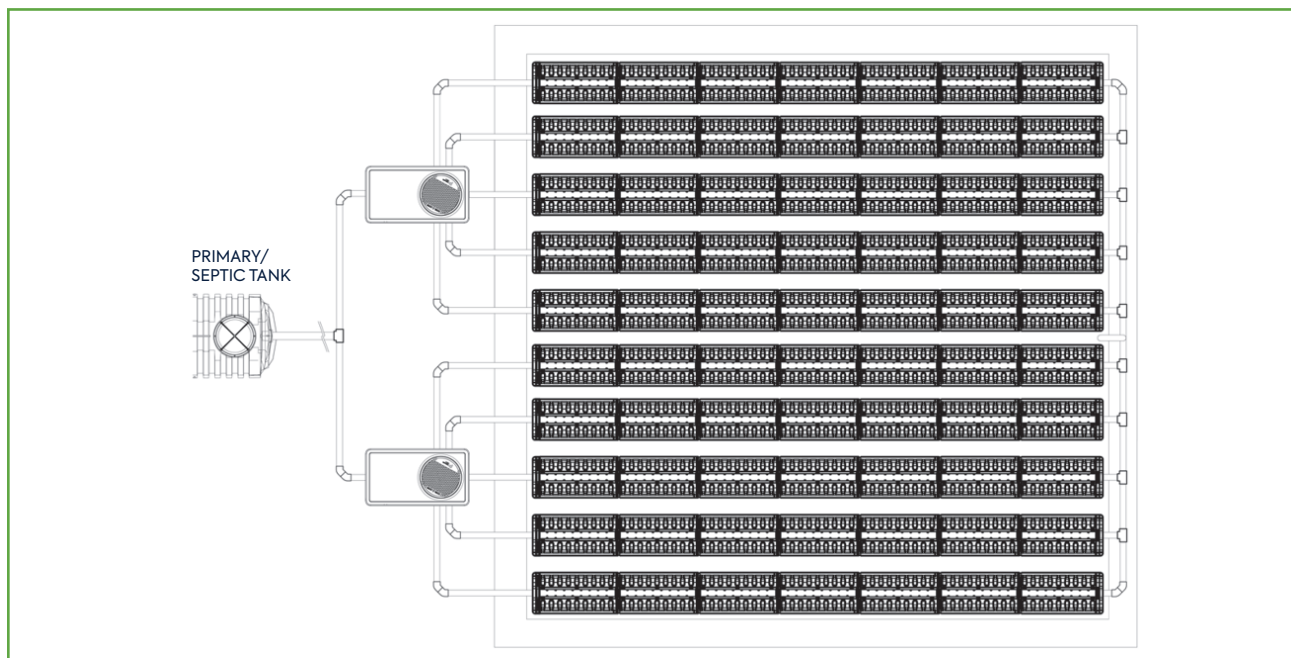

Figure 3.5.1.1 | Ten treatment lines installation fed by two Rewatec dosing distribution boxes

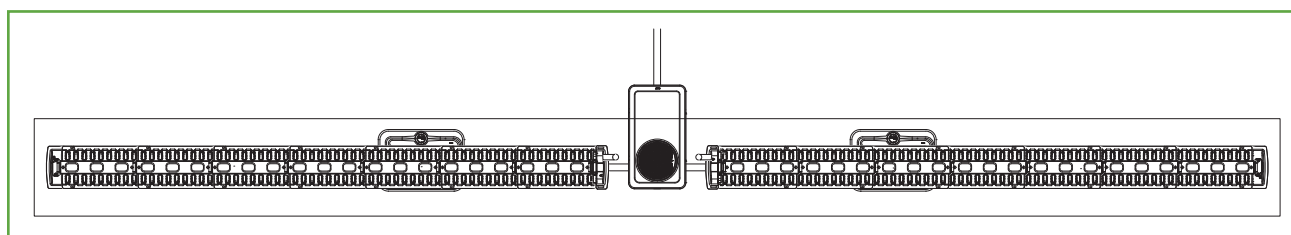

Figure 3.5.1.2 | Two gravity center-fed lines

3.5.2 Pumping station

A pumping station is required when gravity flow cannot be used to convey wastewater from the primary/septic tank to the Ecoflo linear biofilter EL15. The size and configuration of the pumping station must be based on design flow, dosing requirements, and must comply with local regulations.

The pumping station must also be watertight and be equipped with a high-water level float and alarm.

3.5.2.1 Pumped to a distribution box (pump-to-gravity distribution)

A pumping station conveys wastewater from the primary/septic tank to a distribution box that evenly distributes wastewater to each run. Installation must follow the manufacturer's guidance. The distribution box must be installed on compacted soil or on a base to avoid settling. The inlet must be equipped with a velocity reduction device, such as a tee or baffle.

The maximum length of a gravity fed system is 60' (18 m) per run (15 modules).

Premier Tech recommends that the dose to a Ecoflo linear biofilter EL15 treatment module be comprised between 0.12 USG/ft to 0.32 USG/ft (1.5 to 4 L/m) of treatment modules per hydraulic event.

3.5.2.2 Pumped to low-pressure distribution (low-pressure distribution)

A pumping station conveys wastewater from the primary/septic tank into a network of small-diameter perforated pipes inserted within the distribution channels of each treatment module. The pumping station is connected to a distribution network under low pressure to evenly distribute water between the rows of treatment modules. Low-pressure distribution provides an almost uniform distribution of wastewater in all the orifices of the distribution network. The pump pushes the effluent from the primary/septic tank to the rows of treatment modules. As the small diameter of the orifices restricts the water, a pressure is established in the pipe network. As the pressure equilibrates quickly, and as the orifices all have the same diameter, the amount of water reaching each orifice is considered identical.

Drainage orifices drain the line after each pump cycle. The discharge orifice must face upward at 0° (12 o'clock), while the drain orifice faces downward at 180° (6 o'clock).

For additional information on the design and calculation of low-pressure distribution systems, refer to section 5.5.

3.6. DESIGN CRITERIA

3.6.1 Configuration of the dispersal area and the Ecoflo linear biofilter EL15

There are many possible configurations of the Ecoflo linear biofilter EL15 treatment depending on site-specific conditions and topography, the number of rows, the number of treatment modules per row, and the arrangement of these rows on the dispersal area. Table 3 presents the criteria to be considered for the design of a treatment system. Figure 3.6.1 illustrates these different parameters.

Table 3: Ecoflo linear biofilter EL15 main design parameters

Design parameters	Criteria
Linear design loading rate applied to the treatment modules	6.80 gpd/ft 84 L/m·d
Design loading rate applied per treatment module	26.4 gal/module 100 L/module
Maximum length of a row for a gravity or pump-to-gravity system	60' (18 m) (15 modules)
Minimum sand layer height beneath filtration pads A	6" (150 mm)
Minimum width of sand layer beneath filtration pads B	34" (864 mm)
Minimum distance from the end of filtration pads line to the edge of the absorption area C	6" (150 mm) minimum
Width of filtration pads D	15 3/4" (400 mm)
Center-to-center spacing between rows of modules E	34" (864 mm) minimum
Module height F	13" (330 mm)

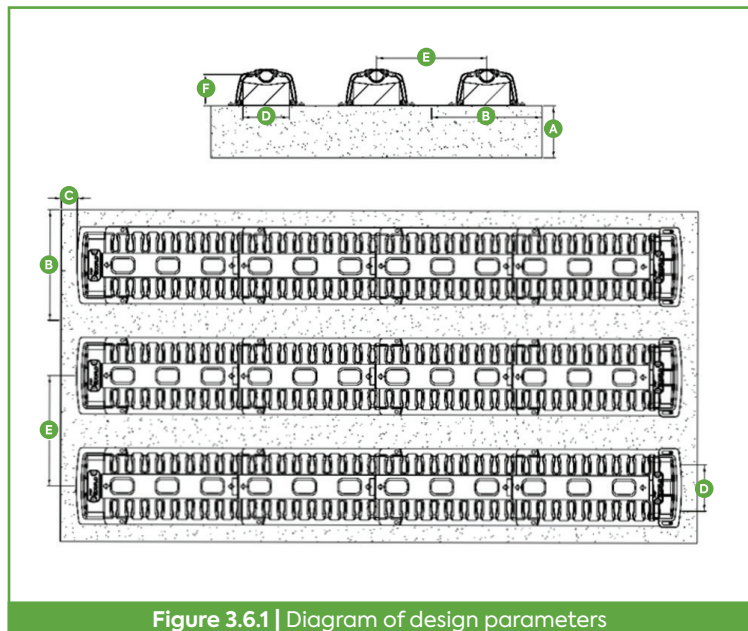

Figure 3.6.1 | Diagram of design parameters

The 6" (150 mm) sand layer is measured from its base (application surface) to the bottom of the treatment modules. It is sized according to design criteria in Table 3. The sand layer must minimally cover the entire surface under the treatment modules and extend at least 6" (150 mm) from the end of each row. The minimal width of the sand layer is 34" (864 mm) per row, on which the filtration pads are centered. System sand consists of typical filtration/septic sand with the following characteristics: an effective diameter (d10) between 0.13 and 0.60 mm with a coefficient of uniformity (Cu) < 8, not more than 5% fines passing through a 0.074 mm sieve, and a percolation time of at least 4 and not more than 12 min/cm.

Premier Tech recommends favoring a long and narrow dispersal bed design on contours. For instance, the longer dimension and module runs (laterals) must be perpendicular to the site slope in trench and bed configurations.

The minimum number of modules is determined by rounding up the following calculation result to the nearest whole number:

$$n_{mod} = \frac{Q}{(LLR \cdot L_{pad})}$$

Round up to nearest whole number

Where:

- Q** Design flow determined per local regulation L/d or USG/d
- LLR** Design linear loading rate per length of filtration pad
6.8 USG/ft-d (84 L/m-d)
- L_{pad}** Length of filtration pad 3.881' (1.183 m)

If the system is composed of more than one row, divide the minimum number of modules required by the number of rows to determine the number of modules per row. Round up to the nearest whole number.

$$n_{mR} = \frac{Q}{(LLR \cdot L_{pad} \cdot n_R)}$$

Round up to nearest whole number

Where:

- n_{mR}** Number of modules per run
- Q** Design flow determined per local regulation L/d or USG/d
- LLR** Design linear loading rate per length of filtration pad
6.8 USG/ft-d (84 L/m-d)
- L_{pad}** Length of filtration pad 3.881' (1.183 m)
- n_R** Number of runs selected

Table 4: Example of minimum number of modules required for most common design flow

Design flow USG/day (L/d)	One treatment line	Two treatment lines	Three treatment lines	Four treatment lines	Five treatment lines
400 (1,500)	15	2 x 8	3 x 5	4 x 4	5 x 3
500 (1,800)	18 P	2 x 9	3 x 6	4 x 5	5 x 4
600 (2,200)	22 P	2 x 11	3 x 8	4 x 6	5 x 5
700 (2,600)	26 P	2 x 13	3 x 9	4 x 7	5 x 6
800 (3,000)	30 P	2 x 15	3 x 10	4 x 8	5 x 6
900 (3,400)	34 P	2 x 17 P	3 x 12	4 x 9	5 x 7

P low-pressure distribution required.

All configurations can be pumped to gravity. An uneven number of modules per run must use low-pressure distribution.

3.7 CONFIGURING THE DISPERSAL AREA AND THE ECOFLO LINEAR BIOFILTER EL15

Premier Tech Water and Environment proposes several possible configurations for the Ecoflo linear biofilter EL15 depending on site constraints. Configurations may be categorized as “bed” or “trench” and as “in-ground”, “elevated/raised”, or at-grade. The sand layer’s minimal height must be 6” (150 mm). When installed on a sloped site, the 6” (150 mm) minimum system sand layer shall be maintained on the thinnest side. Premier Tech recommends favoring a long and narrow dispersal bed design on contours (for instance, placing longer dimension and module runs perpendicular to the site slope).

Dispersal bed sizing and calculations are presented in section 5.

3.7.1 Bed configurations

Bed configurations use a dispersal area where the system sand layer and runs/laterals are placed in parallel over a single continuous soil layer. Figures 3.7.1.1 to 3.7.1.4 illustrate different bed configurations.

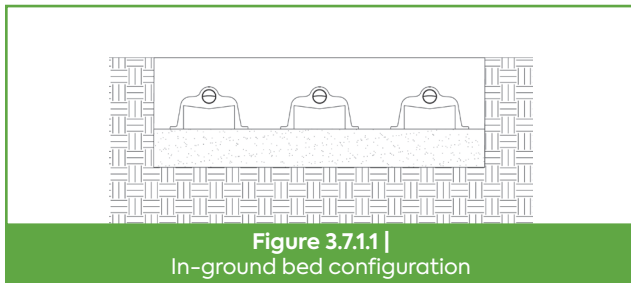

Figure 3.7.1.1 |
In-ground bed configuration

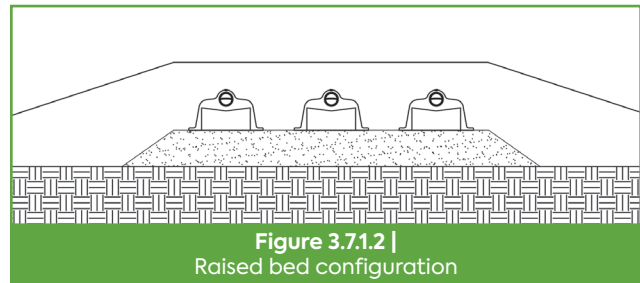

Figure 3.7.1.2 |
Raised bed configuration

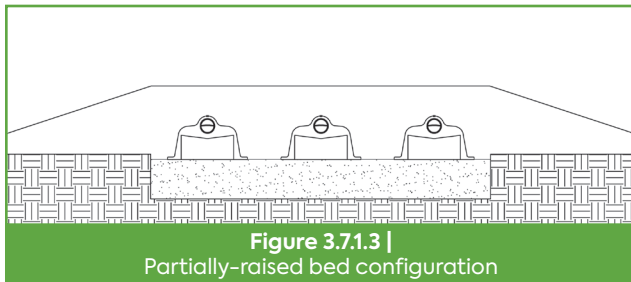

Figure 3.7.1.3 |
Partially-raised bed configuration

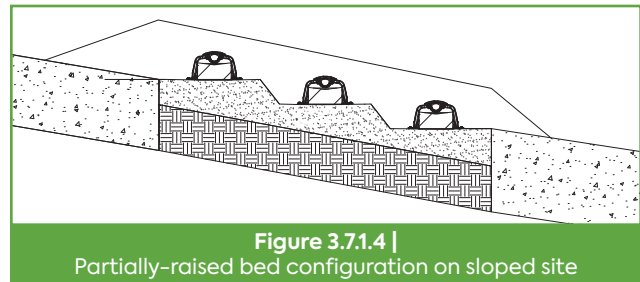

Figure 3.7.1.4 |
Partially-raised bed configuration on sloped site

In elevated/raised configurations, the system sand must be sloped down evenly from the upper limit of the minimum system sand's required width under treatment modules to the outer limit of the absorption area to cover the entire surface of the absorption area, as shown in the figure below.

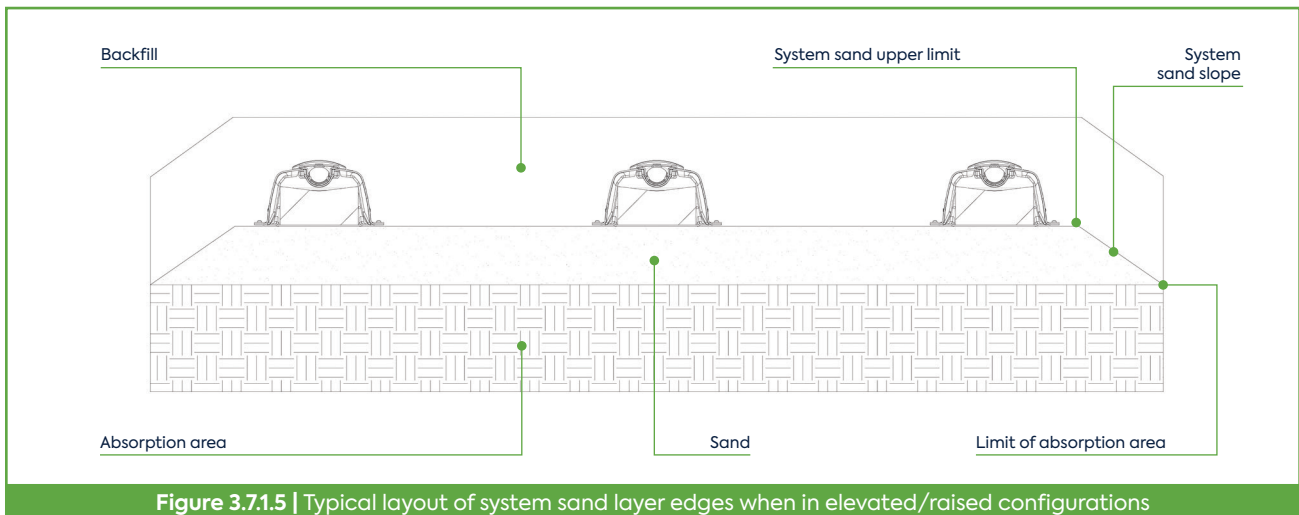

Figure 3.7.1.5 | Typical layout of system sand layer edges when in elevated/raised configurations

3.7.2 Trench configurations

Runs in trench configurations are spaced further apart, each having a separate sand layer. The total bottom area of the trenches must not be less than the dispersal area required for bed configurations. Premier Tech recommends separating trenches by a minimum of 4' (1.2 m) of naturally occurring soil or backfill, or as per local requirements, to provide a hydraulic barrier between consecutive trenches. Figures 3.7.2.1 to 3.7.2.7 illustrate some trench configurations.

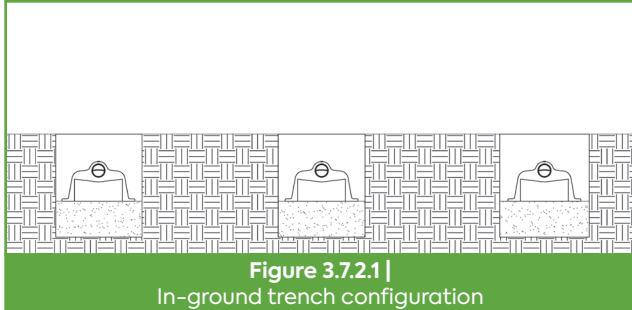

Figure 3.7.2.1 |
In-ground trench configuration

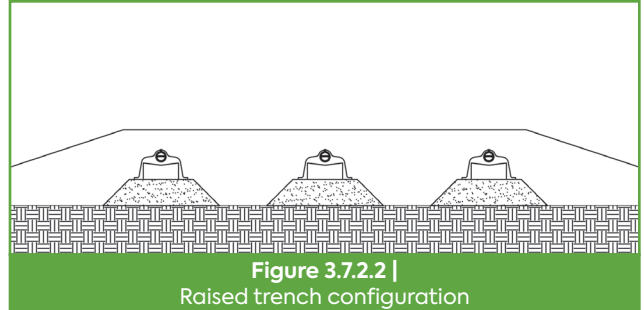

Figure 3.7.2.2 |
Raised trench configuration

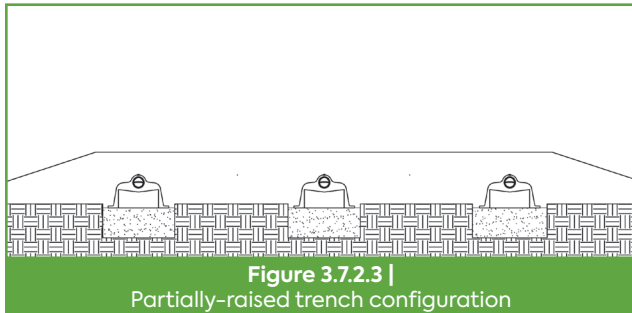

Figure 3.7.2.3 |
Partially-raised trench configuration

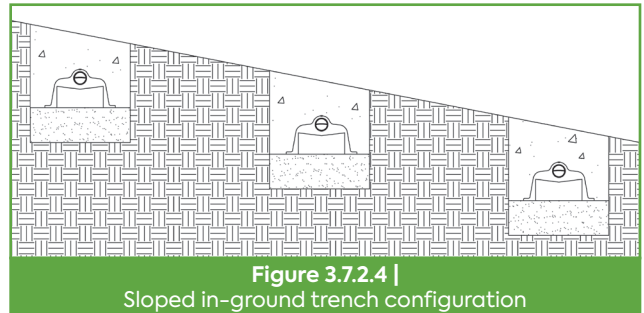

Figure 3.7.2.4 |
Sloped in-ground trench configuration

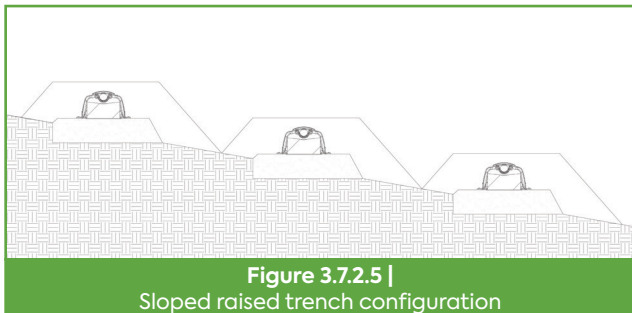

Figure 3.7.2.5 |
Sloped raised trench configuration

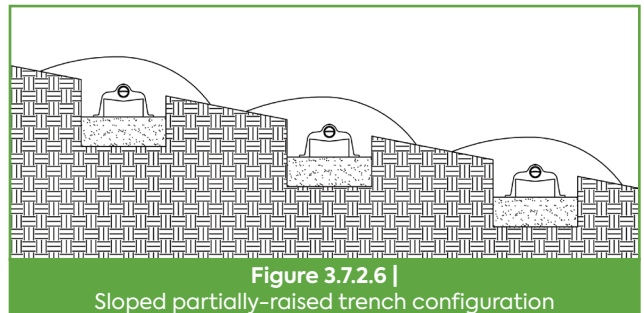

Figure 3.7.2.6 |
Sloped partially-raised trench configuration

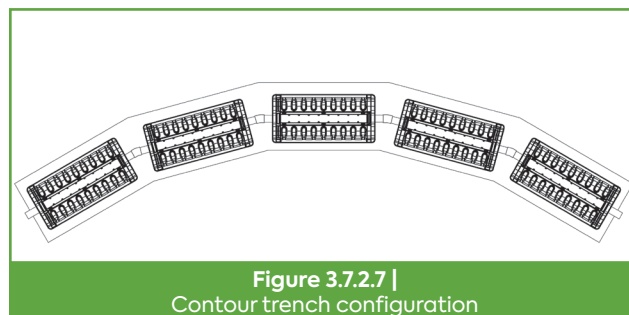
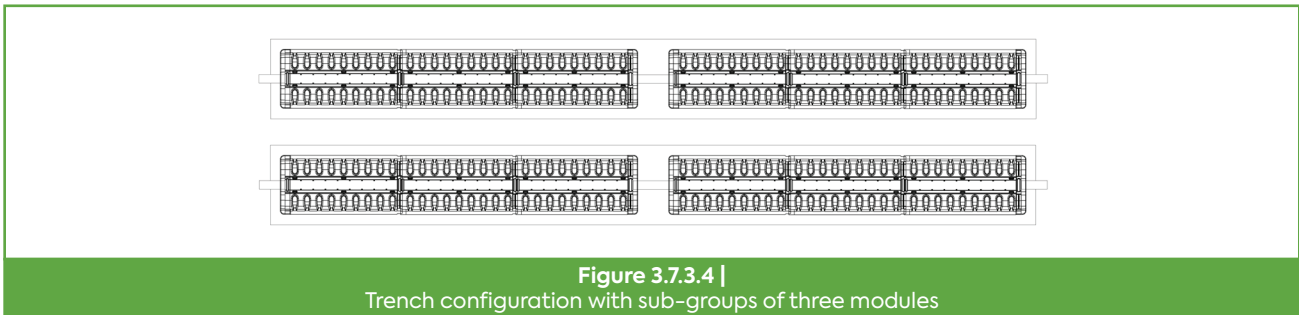
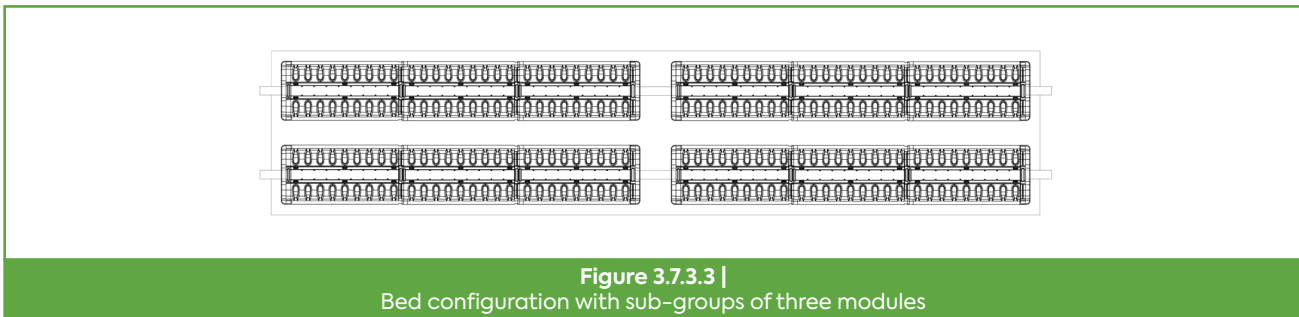
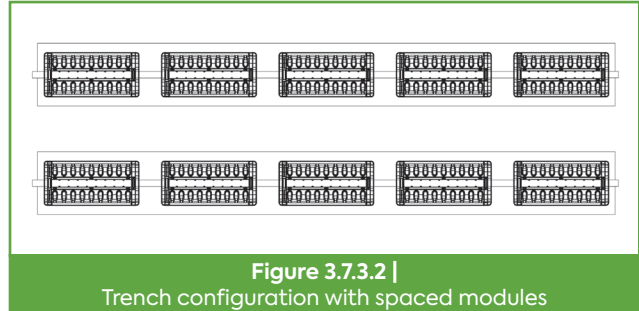
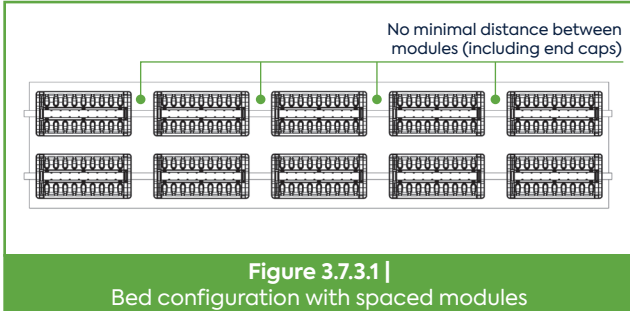

Figure 3.7.2.7 |
Contour trench configuration

3.7.3 Spacing within a run

Spacing between modules within a run is not required. However, modules can be spaced out to give sites with low percolation rates a more balanced dispersal area coverage. This can be done with either a bed or trench, individually, or in sub-group configurations. End caps must always be installed at the end of each sub-group to prevent backfill from entering the modules. Each sub-group can be composed of one or more treatment modules and must be interconnected using a solid pipe.



3.7.4 Split-bed configuration

Split-bed configurations (multiple absorption areas) are site-specific. Please contact a local Premier Tech representative for design assistance if needed.

3.8 SAMPLING DEVICE

The sampling device must be positioned approximately at the third of the length of a row, but not further than the third filtration pad, based on the direction of water flow. Select a row as a reference. The sampling device consists of a sampling tray with a 4" (100 mm) port to collect effluent. Install the sampling tray level beneath the sand layer.

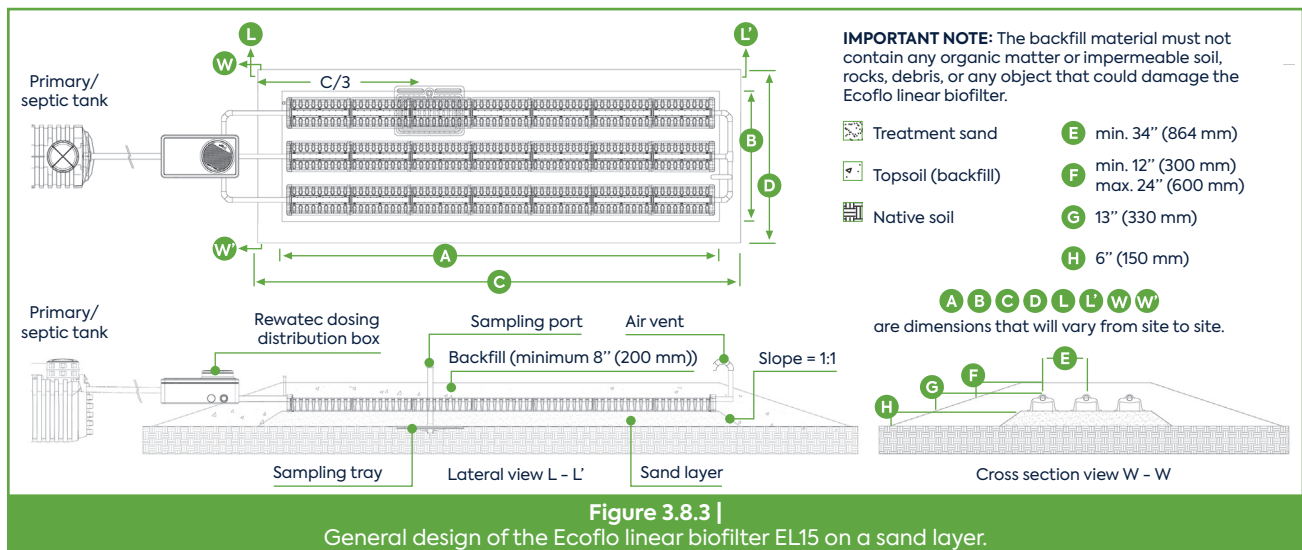
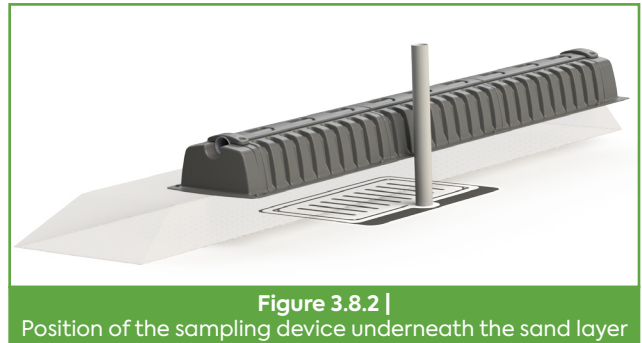

3.9 LIFESPAN OF A FILTRATION PAD

The effective life of an Ecoflo linear biofilter EL15 filtration pad is estimated to be a minimum of 20 years under the following conditions:

- The system has been operated at flow and loading rates not exceeding the rates established in design and in accordance with Premier Tech Water and Environment owner's manual.
- The system has been designed, installed, and maintained in accordance with Premier Tech's guidelines.

3.10 FINAL DISPERSAL

The final dispersal system must be sized in accordance with local regulations/authorities and respecting Premier Tech's guidelines, as applicable (refer to section 5).

4 LOCATION OF WASTEWATER SYSTEM COMPONENTS

4.1 PRIMARY/SEPTIC TANK INSTALLATION CONDITIONS

The primary/septic tank, equipped with an effluent filter, must be located:

- where there is no motorized vehicle traffic
- where it is accessible at all times for maintenance and cleaning
- an area safe from floods and submerging (for example, the primary/septic tank may require a drain around it in presence of high groundwater)

The primary/septic tank must be installed as specified by the manufacturer. It must be watertight and be used for the disposal of domestic wastewater only (for example, no roof water, surface water, or discharge from footing drains). The septic installation must be installed in accordance with the minimum clearances prescribed by local regulations.

4.2 REWATEC DOSING DISTRIBUTION BOX

As applicable, the Rewatec dosing distribution box must be installed according to the following parameters:

- The lid must always be accessible. Never cover it with mulch, soil, or any fixed structure.
- Backfill should be not higher than 2" (50 mm) below the lid once landscaping is complete.
- Never drive a vehicle or place an object weighing more than 500 lb (225 kg) within 10' (3 m) of the Rewatec dosing distribution box.
- Ensure rapid vegetation recovery to avoid erosion.

4.3 ECOFLO LINEAR BIOFILTER EL15

The Ecoflo linear biofilter EL15 must be installed according to the following parameters:

- Never drive a vehicle over an Ecoflo linear biofilter EL15 system.
- Ensure rapid vegetation recovery to avoid erosion.

Complying with these instructions contributes to the septic system's proper functioning and may help increase the Ecoflo linear biofilter EL15's lifespan. Failure to comply with these guidelines may invalidate the warranty at Premier Tech's discretion.

5 EFFLUENT DISPERSAL

The Ecoflo linear biofilter EL15 is a combined treatment and dispersal system. Design and sizing of the treated effluent absorption area must follow local regulations. This is a crucial step for every septic installation.

5.1 HYDRAULIC CONDUCTIVITY

Site assessment and soil conditions are critical to determine the appropriate type of treated effluent discharge. An accurate assessment of the soil's hydraulic conductivity is essential in planning any septic installation. This assessment should be performed following local regulations and will determine if subsurface discharge is possible.

The soil's infiltrative capacity determines the adequate sizing of the soil absorption system. The soil absorption system will ensure the proper infiltration of the treated effluent into the soil at all times. A qualified professional can determine through a field permeability test, laboratory soil particle-size analysis, or any other method approved by local regulations the soil's infiltrative capacity.

Once soil characteristics have been established, the size of the soil absorption system that will receive the Ecoflo linear biofilter's EL15 treated effluent can be determined. The shape of the soil absorption system may vary depending on site constraints and applicable local requirements. Premier Tech recommends favoring long and narrow dispersal bed designs on contour (for example, the longer dimension perpendicular to the site slope).

5.2 VERTICAL SEPARATION TO LIMITING ZONE

The vertical separation available between the proposed soil absorption area to the limiting zone shall comply with local regulations. Local regulations may allow for reduced vertical separation based on the level of treatment provided by the system.

However, Premier Tech Water and Environment recommends that treated effluent be discharged as follows, depending on the vertical separation available between the proposed soil absorption area to the limiting zone.

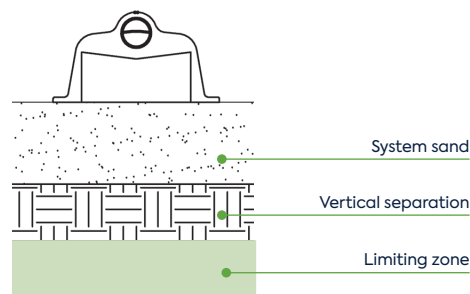

Table 5: Recommendations for the design of absorption area according to vertical separation

Vertical separation (VS) to limiting zone (LZ)	18" (450 mm) to seasonal high-water table 24" (600 mm) to bedrock
Absorption area sizing	Soil loading rate (see section 5.3.1)
Slope	< 8%: L/W - not applicable ≥ 8%: L/W: 4/1

The vertical separation can consist of natural occurring soil, sand, or imported fill.

5.3 DISPERSAL BED AND TRENCH SURFACE SIZING

The total surface of required absorption area is calculated using soil hydraulic loading rates (Table 6). Soil characteristics and the peak daily flow (gpd) are required to perform this calculation:

$$S = \frac{Q}{LR_{soil}}$$

Where:

- S** Surface of absorption area
- Q** Design flow rate (USG/d)
- LR_{soil}** Application rate (gpd/ft²) (Table 6)

Table 6: Application rates established using soil excavation

Soil characteristics		Application rates (gallons per square foot per day)			
Texture	Structure type ¹	In-ground trench	In-ground bed	At-grade leachfield	Leachfield in a bottomless sand filter
Very coarse sand	SG	See § 1-919(b)	See § 1-919(b)	2.00	2.00
Coarse sand, sand	SG	3.00	2.40	2.00	2.00
Loamy coarse sand, loamy sand	SG	3.00	2.40	2.00	2.00
Fine sand, very fine sand, loamy fine sand, loamy very fine sand	SG	2.00	1.60	1.60	1.60
	MA/PL	1.00	0.80	0.80	0.80
	PR/ABK/SBK/GR	1.40	1.20	1.20	1.20
Coarse sandy loam, sandy loam	MA/PL	1.00	0.80	0.80	0.80
	PR/ABK/SBK/GR	1.40	1.20	1.20	1.20
Fine sandy loam, very fine sandy loam	MA/PL	1.00	0.80	0.80	0.80
	PR/ABK/SBK/GR	1.20	1.00	1.00	1.00
Loam	MA/PL	1.00	0.80	0.80	0.80
	PR/ABK/SBK/GR	1.20	1.00	1.00	1.00
Silt loam, silt	MA/PL	0.60	0.40	0.40	N/A
	PR/ABK/SBK/GR	0.80	0.60	0.60	N/A
Sandy clay loam, clay loam, silty clay loam	MA/PL	0.50	0.40	0.40	N/A
	PR/SBK/GR	0.60	0.40	0.40	N/A
Sandy clay, clay, silty clay		N/A (See § 1-926)			

Adapted from J. Tyler, 2000.

¹ The abbreviations used for structure are: SG = single grain; GR = granular; MA = massive; PL = platy; PR = prismatic; ABK = angular blocky; SBK = subangular blocky.

5.3.1 Slope ≤ 4%

The Ecoflo linear biofilter system must be centered onto the absorption area surface. If the system is composed of a single run, the treatment modules must be centered onto the entire area. If the system is composed of several runs, they must be evenly spaced apart and centered onto the absorption area.

To center and evenly distribute runs of Ecoflo linear biofilter modules onto the absorption area (figure 5.3.1), distances to the edge of the absorption area and between each lateral can be calculated as follows:

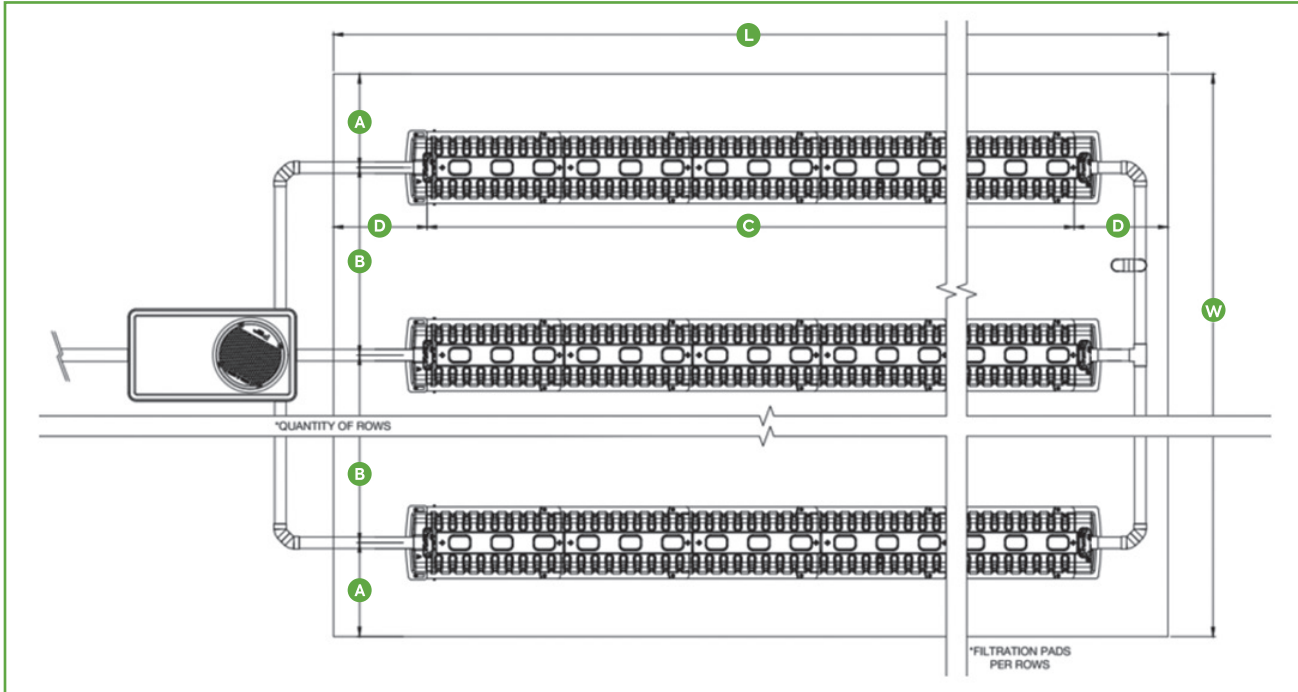

Figure 5.3.1 | Typical bed layout — Slope between 0 to 4%

A	B	C	D	L	W
$\left(\frac{-(2Cn_R) + \sqrt{(2Cn_R)^2 + (16Sn_R)}}{8n_R} \right)$	2A	$L_{pad} \times n_{mR}$	A For centered system A=D	C+2D	$2A + (n_R - 1)B$

S Surface of absorption area required (refer section 5.2 for absorption area sizing)

n_R Number of runs chosen

n_{mR} Number of modules per run = round up $\left(\frac{Q}{LLR \cdot L_{pad} \cdot n_R} \right)$

Q Daily flow rate (L/d) or un USG/d

LLR Linear loading rate on filtration pad 6.44 UGS/ft.d (80 L/m.d)

L_{pad} Length of filtration pad 3.881' (1.183 m)

5.3.2 Slope > 4%

In the presence of only one run, the lateral shall be located maximum 2' (600 mm) from the up slope edge of the absorption area. In cases of multiple run, as shown in figure 5.3.2, the first lateral is located maximum 2' (600 mm) from the up slope edge of the absorption area, and the other laterals are evenly spaced down slope from the upper lateral and up slope of the midpoint of the absorption area width, while respecting the minimum distances between lines or edge of the absorption bed, as specified in table 3 and figure 3.6.1.

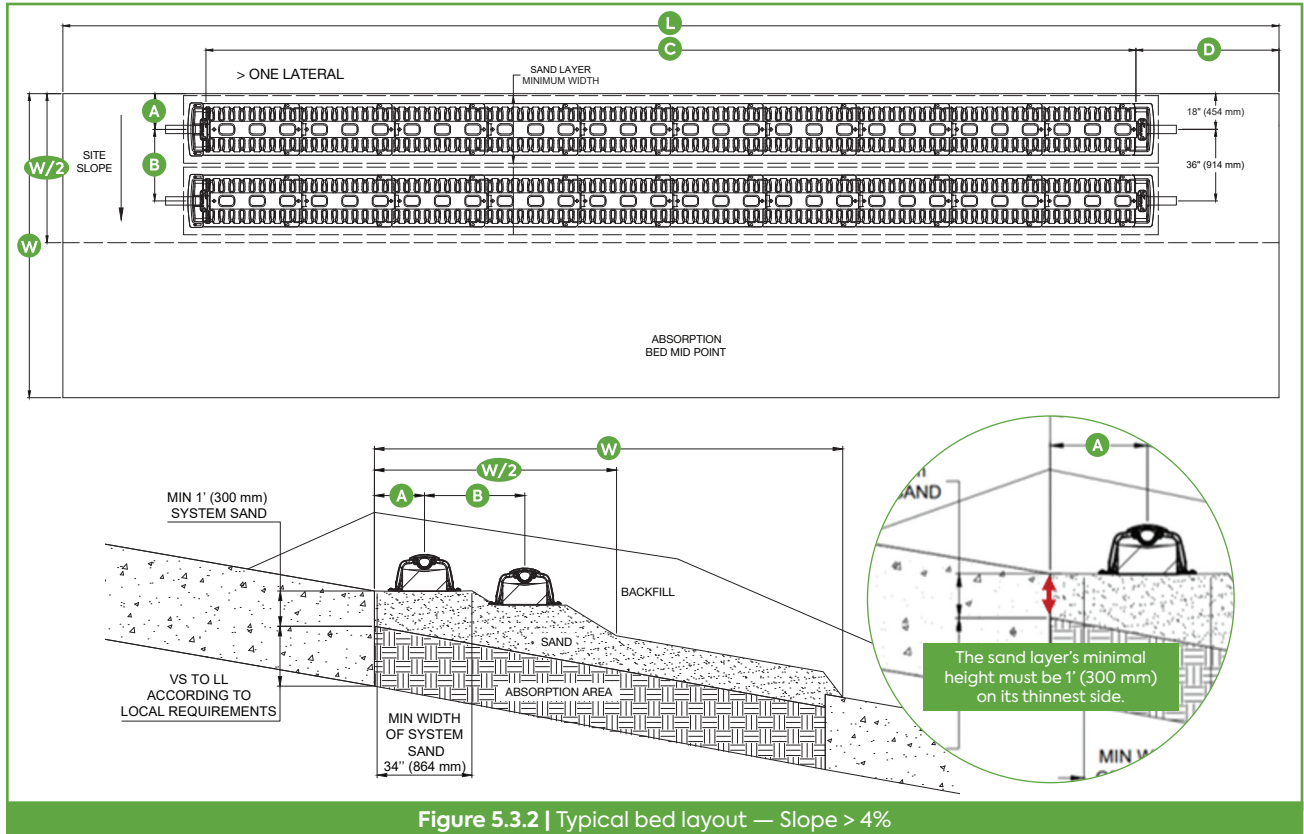

Figure 5.3.2 | Typical bed layout — Slope > 4%

The area down slope of the midpoint provides additional polishing through lateral filtration and increased infiltration capacity onto the contact area.

Minimum length of the absorption area is equal to: $L_{min} = L_{pad} \cdot n_{mR} + 2' (600 \text{ mm})$ (for the end caps).

Absorption area width is then equal to: $W = S/L_{min}$.

While long and narrow dispersal bed designs shall be favored, there is no length to width ratio that applies for slopes < 8%.

For slopes >4%, a 4:1 minimum length to width ratio for dispersal bed design is recommended.

5.3.3. Spacing within a run

Sloped sites with low percolation rates or shallow soil situations may require for modules to be spaced-out individually or in sub-groups to create a more balanced coverage of the dispersal area.

$$D_{SG} = \frac{L - (n_{mR} \cdot L_{pad}) - (n_{SG} \cdot (L_{ic} + L_{ec}))}{n_{SG}}$$

$$D = D_{SG} / 2$$

Where:

- D_{SG} Distance between sub-groups of modules
- n_{mR} Number of modules per run = round up $\frac{Q}{(LLR \cdot L_{pad} \cdot n_r)}$
- n_{SG} Number of sub-groups selected
- L Length of absorption area
- L_{pad} Length of filtration pad 3.881' (1.183 m)
- L_{ic} Length of inlet cap 7.6875" (0.195 m)
- L_{ec} Length of end cap 16.375" (0.415 m)
- D Distance of a run to the edge of the bed or trench length as shown on figure 3.7.1.5

To evenly distribute the modules or sub-group of modules along the total length of the absorption area, proceed as shown.

A more balanced coverage of the absorption area length can also be achieved by adding complementary modules as necessary, considering a maximum of 6' (2 m) from the end of a run to the edge of the bed.

5.4 SYSTEM VENTILATION

When gravity distribution is used with the Ecoflo linear biofilter EL15, a building's plumbing vent(s) is used to provide proper aeration. Where this is not possible, the vent is typically a 4" (100 mm) diameter non-perforated pipe that is extended above natural ground level. The vent should be located close to the extremity of the distribution system or to the end of rows of interconnected runs. The vent can also be positioned to a convenient location. Ensure that the pipe does not have any bends that will allow condensation to pond in the pipe. This may close off the vent line. The pipe must have an invert higher than the system so that it does not drain effluent.

In cases where a pumping station is used, it must have adequate ventilation to avoid buildup of harmful gases, air lock, and corrosion, and, most importantly, ensure proper aeration of the treatment system. This can be accomplished by using

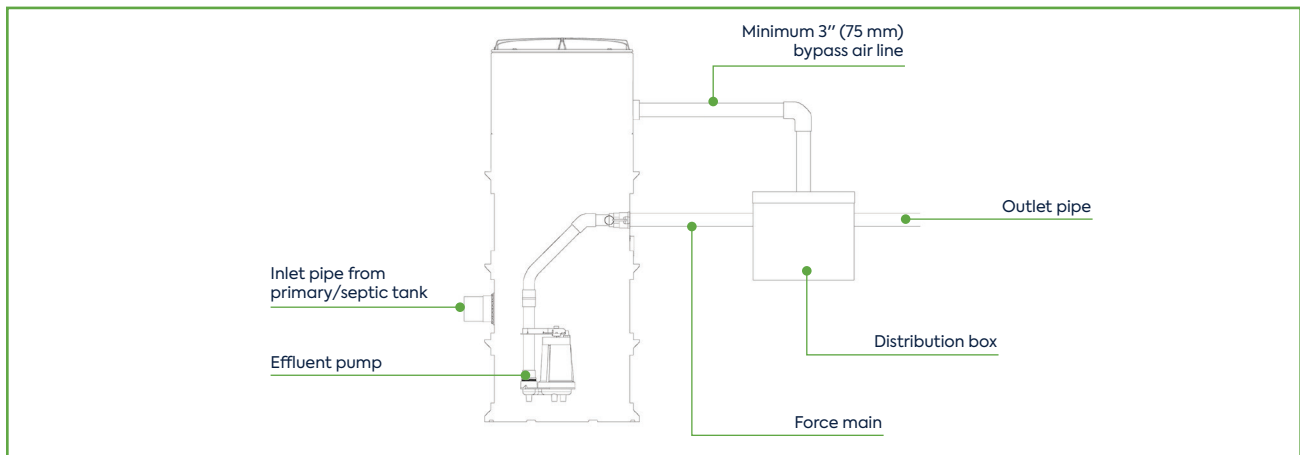

Figure 5.4.1 | Pump-to-gravity installation schematic

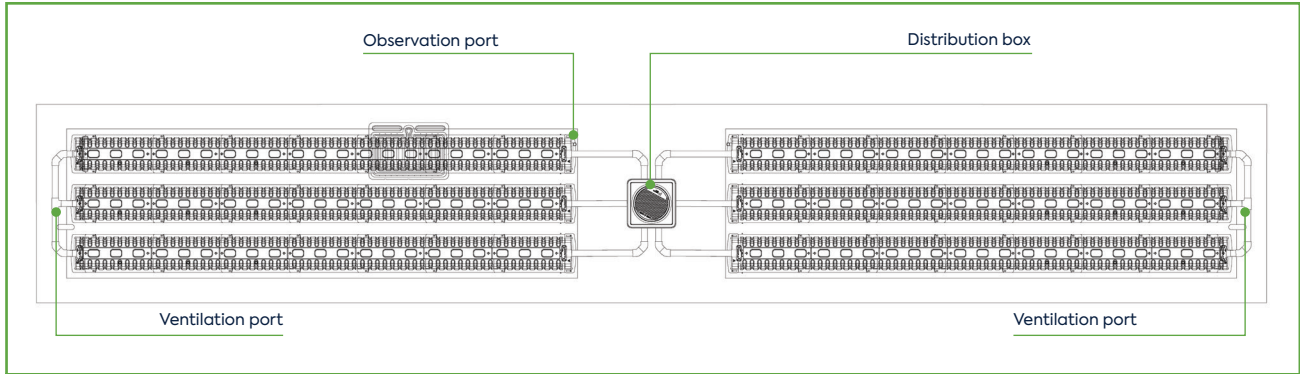

Figure 5.4.2 | Schematic of the ventilation of the Ecoflo linear biofilter EL15 with clusters of treatment modules

a separate vent pipe to the pump chamber, distribution box, or wherever practical, as shown in figure 5.4.1. Note that an installation with clusters of treatment modules needs individual ventilation ports for each module, as shown in figure 5.4.2.

5.5 LOW-PRESSURE SYSTEM CONFIGURATION

Low-pressure distribution calculations determine orifice size, ensure that the flow is equally divided to every orifice, and that the residual pressure results in a minimum of 2' (600 mm) squirt height at the distal end of the furthest run. The ends of each run require flushing ports to maintain the free flow of effluent from orifices at their distal ends.

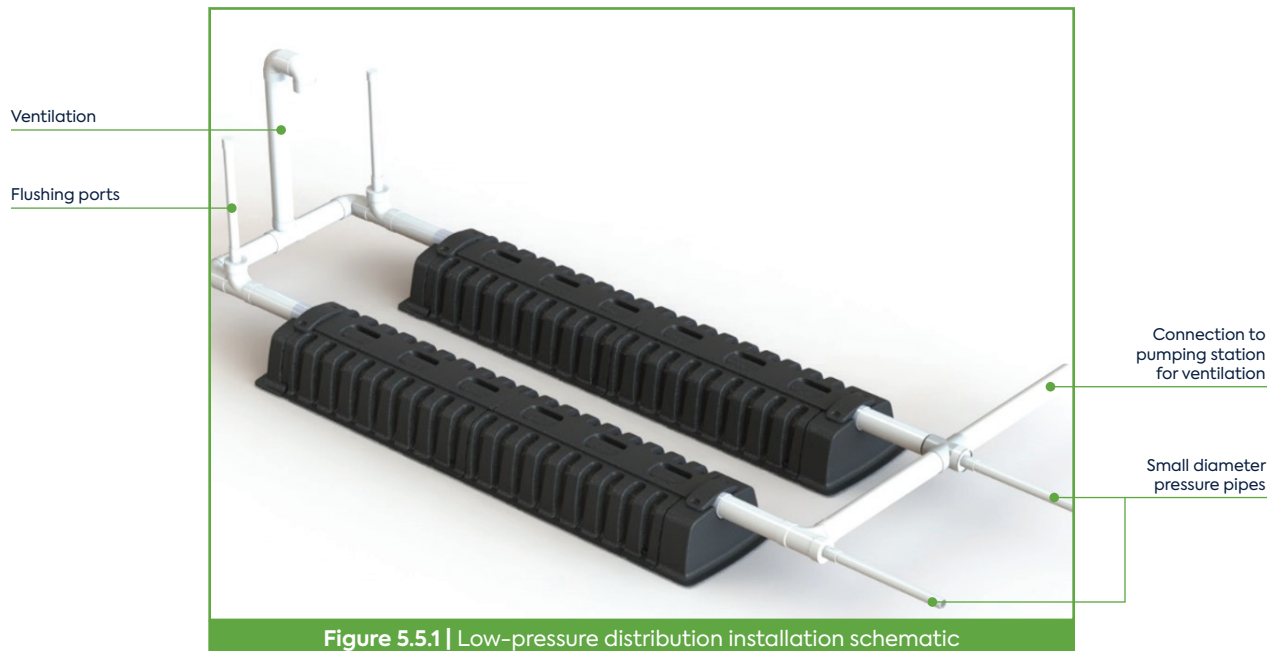

Figure 5.5.1 | Low-pressure distribution installation schematic

The calculation of low-pressure dosing implies that the design should comprise equally-sized lateral lengths and zones as required.

Pressurized distribution designs must account for elevation differences and for pressure drops in the pump system, force main, distribution valve(s), distribution manifold, and laterals themselves, all of which must be included in the calculation.

A summary of design elements follows:

- Specify force main and manifold lengths and determine their sizing (internal diameter). Typical force main sizing should be between 1.25" (32 mm nominal) and 2" (50 mm nominal).
- Specify the static elevation difference between the low water level in the dosing pump chamber and the highest element in the system (either the highest lateral or distribution valve), then add the required residual pressure.
- Determine the number of runs and their lengths, as explained in the previous section.
- Specify an orifice spacing: the recommended orifice spacing is 3' (900 mm) (minimum one hole per module) along the lateral for even distribution of effluent. The number of orifices per laterals and the space from orifice to edge can then be calculated.
- Specify a number of drain orifices. Drain orifices must be evenly spaced, facing downward, on each lateral to allow drain-out and to prevent freezing between pump cycles. Premier Tech recommends having a drain orifice at the first module, the last module, and every third module between.
- Specify an orifice size: the minimum size is 3/16" (4.75 mm nominal). Note that the orifice size is very important in the flow/pressure calculations and that their spacing can be varied to modify the flow.
- Specify a distal squirt height: a minimum of 2' (600 mm) is required. The distal squirt height's specified values are used in the iterative process to confirm that the actual discharge rate of the pump fits with system design. By selecting different squirt heights, a system curve can be plotted using the newly calculated total head and capacity that intersects with the pump's performance curve. The point of intersection indicates the actual system discharge flow rate.
- From these data, it is possible to calculate the flow through each lateral and the total discharge rate.
- Evaluate pump discharge assembly and system fittings losses.
- Calculate pressure drops in the pump discharge, force main, fittings, valves, etc., up to the manifold.
- Calculate the pressure drop in the lateral, accounting for flow reduction at each orifice. Premier Tech recommends to design the orifice sizing and spacing so that the difference in flow within the laterals has less than 5% between the first and last orifice. Typical lateral sizing should be between 1.25" (32 mm nominal, minimum), and 2" (50 mm nominal).

FOR DESIGN SUPPORT CONTACT OUR REGIONAL SUPERVISOR.

If you have any questions or comments, do not hesitate
to contact Premier Tech at **1 800 632-6356**.



PT Water and Environment

+1 800 632-6356

info.ptwe.na@premiertech.com

PT-WaterEnvironment.com



The information contained in this document was up-to-date and consistent with the information available at the time of publication. Premier Tech Ltd and its affiliated companies make no warranties or representations as to its accuracy. Because of its continuous improvement policy, Premier Tech Ltd and its affiliated companies reserve the right to change and/or discontinue the manufacture of any product and/or modify technical data and prices, for any reason whatsoever and at its sole discretion, without further notice and without liability to anyone in this regard. ECOFLO®, PREMIER TECH® and PREMIER TECH & DESIGN™ are trademarks of Premier Tech Ltd or its affiliates. For current data regarding all patent application(s) and patent(s) for this product or any part thereof, consult the website patentmarking.premiertech.com, with the following references: 1596, 2777, and 8296.

© 2023 Premier Tech Ltd. All rights reserved.